



2 Function with Slim Transmitter

SYSTEM PART NUMBER

113002 2 Function Mini Receiver + 2 Function Slim Transmitter



CONTENTS

1 x Mini Receiver
1 x Slim Transmitter
1 x Lanyard
1 x Instructions

REPLACEMENT TRANSMITTER

TX3002 - 2 Function Slim Transmitter

REPLACEMENT RECEIVER

11RX02 - 2 Function Mini Receiver

TRANSMITTER SPECIFICATION

ENCLOSURE

Material ABS
Switch Type 12mm Dome Switch Functions
Functions 2
Identification Pockets for printed text or image insertion

RF

Modulation 2-GFSK. Gaussian Frequency Shift Keying
Frequency 433.050 MHz to 434.790 MHz
902.025 MHz– 927.975 MHz
Channels 32
Channel Selection Fixed
Channel hopping
Technology Hand-held Transmitter
Temperature Range -40° C to + 80° C (-40° F to + 176° F). Use Lithium for lower temperatures
Range 60m (200ft)
Aerial Internal – printed on PCB
Transmitted power < 0.4mW Typical

POWER

Batteries 2 x AA – 3 volts.
Quiescent Current 5µA
Current Standby (SET) 2mA
Current Transmitting 30mA

SAFETY & PROTECTION

IP Rating 54
Reverse Polarity Protection Protected

INDICATOR

Type 1 x Red LED
Off Transmitter is OFF and in standby mode
Slow flash Transmitter is ON and ready for use (The SET Button has been pressed and released)
On Transmitting (A STOP, SET or Function Button is being pressed)
Fast flash Transmitting – Indication that the battery will need replacing soon

COMPLIANCE

FCC	FCC CFR 47-part 15.231 FCC CFR 47-part 15.109 433.050MHz to 434.790MHz FCC CFR 47-part 15.249 FCC CFR 47-part 15.109 902.025MHz to 927.975MHz
IC	ISED RSS-210 Issue 9 ISED RSS-GEN Issue 4 ICES-003 Issue 6. 433.050MHz to 434.790MHz ISED RSS-210 Issue 9 ISED RSS-GEN Issue 5 ICES-003 Issue 6. 902.025MHz to 927.975MHz
CE	RED Directive ETSI EN 300 220-2 v3.2.1 ETSI EN 300 220-1 v3.1.1. ETSI EN 301 489-17 V3.1.1 ETSI EN 301 489-1 V2.1.1 433.050MHz to 434.790MHz
Australia/NZ	ETSI EN 300 220-2 v3.2.1 ETSI EN 301 489-1 v3.1.1 433.050MHz to 434.790MHz 915.025MHz to 927.975MHz
RoHS	Directive 2011/65/EU

RECEIVER SPECIFICATION

ELECTRICAL

Voltage Nominal	12/24V DC
Voltage Min/Max	8 to 36V DC
Connection	1.5m (5ft) 7 core cable through gland
Switch Type	MOSFET (Positive Switching)
Functions	2

RF

Modulation	2-GFSK. Gaussian Frequency Shift Keying
Frequency	433.050 MHz to 434.790 MHz
Channels	1/32
Channel Selection	Fixed/Channel Hopping
Technology	Fixed Receiver
Temperature Range	-40° C to + 80° C (-40° F to + 176° F)
Range	60m (200ft)
Registration Codes	Over 16 million

CURRENT CAPACITY

FET Rating	7.5A
System Rating	7.5A
Quiescent Current	31mA 12V/ 17mA 24V on Standby (Not SET)
Power rating	100W

AERIAL

Aerial	Internal – ¼ wave wire
Aerial option	SMA Connector on PCB – order separately
External Antenna	AC9860/1/2/3 & 9 – order separately

SAFETY & PROTECTION

Back EMF	Yes – Diode Protection
Reverse Polarity	Yes
System Monitoring	Yes – using a secondary processor
Transient Voltage	Yes – TVS Diode 30.8 volts. 10amp fuse recommended
Overload	Yes – by temperature sensor

CONFIGURATION

Operating System Lodar Script
Functions Momentary with Horizontal Interlocks
Master Output Parallel – Continuous optional

INFORMATION

Fault code Yes LED
Receive Indication Yes LED

PACKAGING

Brown Box with coloured sleeve

ENCLOSURE

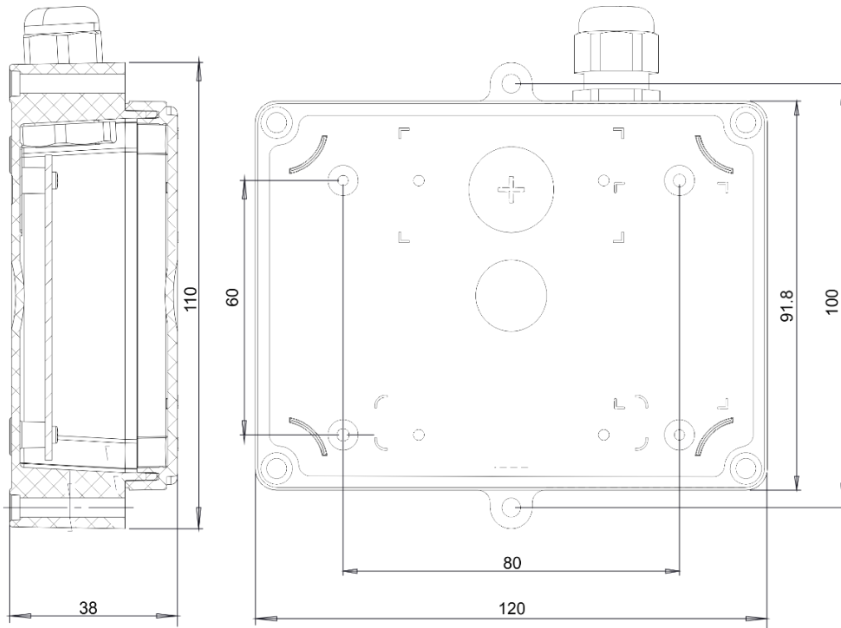

Material Lid Clear PVC - to view LEDs
Base Black ABS
Dimensions 120 x 110 x 38mm (4.72 x 4.33 x 1.5ins.)
Weight 290 gms.
Breather Gortex membrane
IP Rating IP55
Functional Identification LED though clear lid
Mounting 4 external lugs
Fixings 5mm (3/16") - not supplied

COMPLIANCE

REG 10 EC Type-approval mark E11 037601
 EC Type-approval No: e11/72/245*2009/19*7601*00

FCC FCC CFR 47 Part 15.109
 433.050MHz to 434.790MHz

IC ICES-003 Issue 6.
 433.050MHz to 434.790MHz

CE RED Directive
 ETSI EN 300 220-2 v3.2.
 ETSI EN 300 220-1 v3.1.1.
 ETSI EN 301 489-17 V3.1.1,
 ETSI EN 301 489-1 V2.1.1
 433.050MHz to 434.790MHz

Australia/NZ ETSI EN 300 220-2 v3.2.1
 ETSI EN 301 489-1 V2.1.1
 433.050MHz to 434.790MHz

RoHS Directive 2011/65/EU