



## 2 Function with Slim Transmitter

### SYSTEM PART NUMBER

**113000** 2 Function Mini Receiver + 2 Function Slim Transmitter. No Master

### CONTENTS

1 x Mini Receiver  
1 x Slim Transmitter  
1 x Lanyard  
1 x Instructions



### REPLACEMENT TRANSMITTER

**TX3002** - 2 Function Slim Transmitter

### REPLACEMENT RECEIVER

**11RX00** - 2 Function Mini Receiver. No Master

### TRANSMITTER SPECIFICATION

#### ENCLOSURE

Material ABS  
Switch Type 12mm Dome Switch Functions  
Functions 2  
Identification Pockets for printed text or image insertion

#### RF

Modulation 2-GFSK. Gaussian Frequency Shift Keying  
Frequency 433.050 MHz to 434.790 MHz  
902.025 MHz– 927.975 MHz  
Channels 32  
Channel Selection Fixed  
Channel hopping  
Technology Hand-held Transmitter  
Temperature Range -40° C to + 80° C (-40° F to + 176° F). Use Lithium for lower temperatures  
Range 60m (200ft)  
Aerial Internal – printed on PCB  
Transmitted power < 0.4mW Typical

#### POWER

Batteries 2 x AA – 3 volts.  
Quiescent Current 5µA  
Current Standby (SET) 2mA  
Current Transmitting 30mA

#### SAFETY & PROTECTION

IP Rating 54  
Reverse Polarity Protection Protected

#### INDICATOR

Type 1 x Red LED  
Off Transmitter is OFF and in standby mode  
Slow flash Transmitter is ON and ready for use (The SET Button has been pressed and released)  
On Transmitting (A STOP, SET or Function Button is being pressed)  
Fast flash Transmitting – Indication that the battery will need replacing soon

## COMPLIANCE

FCC	FCC CFR 47-part 15.231 FCC CFR 47-part 15.109 433.050MHz to 434.790MHz FCC CFR 47-part 15.249 FCC CFR 47-part 15.109 902.025MHz to 927.975MHz
IC	ISED RSS-210 Issue 9 ISED RSS-GEN Issue 4 ICES-003 Issue 6. 433.050MHz to 434.790MHz ISED RSS-210 Issue 9 ISED RSS-GEN Issue 5 ICES-003 Issue 6. 902.025MHz to 927.975MHz
CE	RED Directive ETSI EN 300 220-2 v3.2.1 ETSI EN 300 220-1 v3.1.1. ETSI EN 301 489-17 V3.1.1 ETSI EN 301 489-1 V2.1.1  433.050MHz to 434.790MHz
Australia/NZ	ETSI EN 300 220-2 v3.2.1 ETSI EN 301 489-1 v3.1.1 433.050MHz to 434.790MHz 915.025MHz to 927.975MHz
RoHS	Directive 2011/65/EU

## RECEIVER SPECIFICATION

### ELECTRICAL

Voltage Nominal	12/24V DC
Voltage Min/Max	8 to 36V DC
Connection	1.5m (5ft) 7 core cable through gland
Switch Type	MOSFET (Positive Switching)
Functions	2

### RF

Modulation	2-GFSK. Gaussian Frequency Shift Keying
Frequency	433.050 MHz to 434.790 MHz
Channels	1/32
Channel Selection	Fixed/Channel Hopping
Technology	Fixed Receiver
Temperature Range	-40° C to + 80° C (-40° F to + 176° F)
Range	60m (200ft)
Registration Codes	Over 16 million

### CURRENT CAPACITY

FET Rating	7.5A
System Rating	7.5A
Quiescent Current	31mA 12V/ 17mA 24V on Standby (Not SET)
Power rating	100W

### AERIAL

Aerial	Internal – ¼ wave wire
Aerial option	SMA Connector on PCB – order separately
External Antenna	AC9860/1/2/3 & 9 – order separately

### SAFETY & PROTECTION

Back EMF	Yes – Diode Protection
Reverse Polarity	Yes
System Monitoring	Yes – using a secondary processor
Transient Voltage	Yes – TVS Diode 30.8 volts. 10amp fuse recommended
Overload	Yes – by temperature sensor

### CONFIGURATION

Operating System      Lodar Script  
Functions                Momentary with Horizontal Interlocks  
Master Output          N/A

### INFORMATION

Fault code              Yes      LED  
Receive Indication    Yes      LED

### PACKAGING

Brown Box              with coloured sleeve

### ENCLOSURE

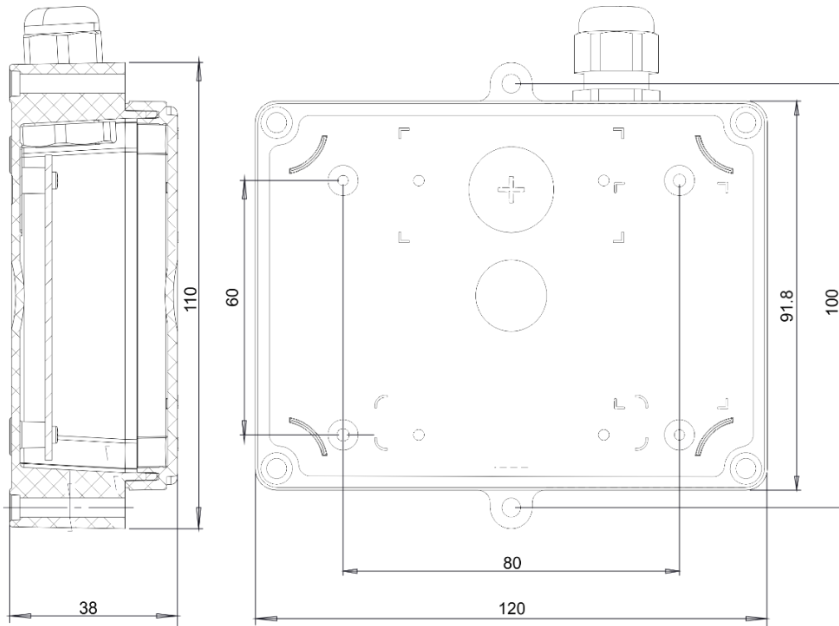

Material Lid              Clear PVC - to view LEDs  
Base                        Black ABS  
Dimensions                120 x 110 x 38mm (4.72 x 4.33 x 1.5ins.)  
Weight                      290 gms.  
Breather                  Gortex membrane  
IP Rating                  IP55  
Functional Identification    LED though clear lid  
Mounting                  4 external lugs  
Fixings                      5mm (3/16") - not supplied

### COMPLIANCE

REG 10                    EC Type-approval mark E11 037601  
                                 EC Type-approval No: e11/72/245\*2009/19\*7601\*00

FCC                         FCC CFR 47 Part 15.109  
                                 433.050MHz to 434.790MHz

IC                          ICES-003 Issue 6.  
                                 433.050MHz to 434.790MHz

CE                         RED Directive  
                                 ETSI EN 300 220-2 v3.2.  
                                 ETSI EN 300 220-1 v3.1.1.  
                                 ETSI EN 301 489-17 V3.1.1,  
                                 ETSI EN 301 489-1 V2.1.1  
                                 433.050MHz to 434.790MHz

Australia/NZ              ETSI EN 300 220-2 v3.2.1  
                                 ETSI EN 301 489-1 V2.1.1  
                                 433.050MHz to 434.790MHz

RoHS                      Directive 2011/65/EU